

RECOIL

REC1 F0037

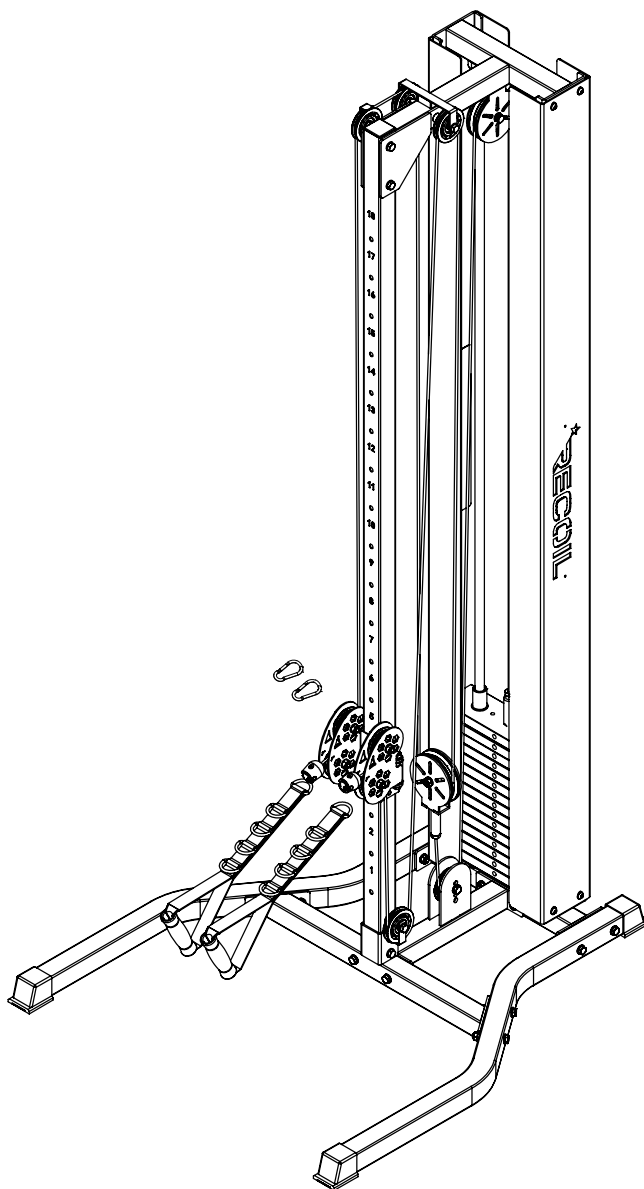

Read all precautions and instructions in this manual before using this equipment

Assembly Caution	-----	3
Part List	-----	4
Hardware List	-----	4
Step 1	-----	5
Step 2	-----	6
Step 3	-----	7
Step 4	-----	8
Step 5	-----	9
Step 6	-----	10
Step 7	-----	11
Step 8	-----	12
Step 9	-----	13
Step 10	-----	14

ASSEMBLY CAUTION

Please carefully read the following information before installation

Assembling requires at least two people

Do not tighten all screws before assembly is complete

Ensure that all accessories are complete.

Shortcut: A Lot of People Doing That Way

To enhance your installation process for both speed and convenience, consider removing all accessories from the box, carefully opening the packaging, and arranging everything neatly on the floor. This preparation can streamline your setup experience.

The following tools might help you improve your installation experience

- Adjustable wrenches

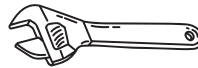

- Rubber hammers

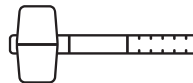

- Socket set

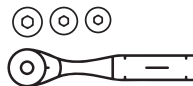

- Electric Wrench

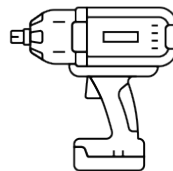

WARNING



Choking hazard. Small parts-Please exercise caution if smallchildren or pets are present.





Sharp objects may be involved. Use precaution and protection.



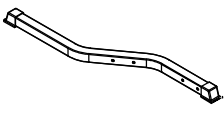
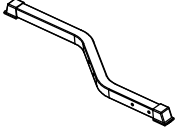
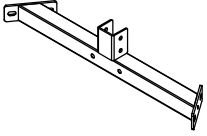
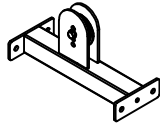
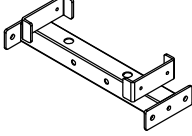
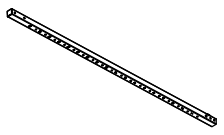
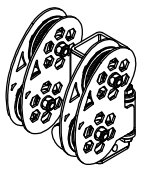
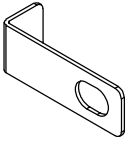
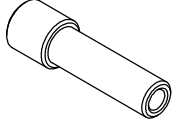
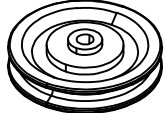
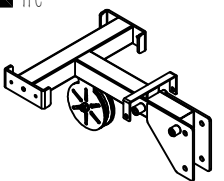
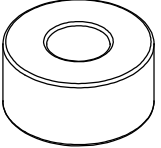
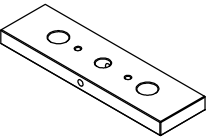
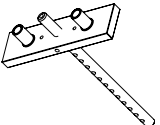
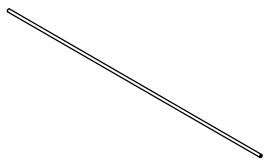
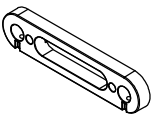
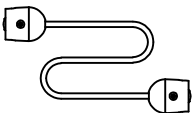

Heavy object. Use lifting aids and proper lifting techniques when moving

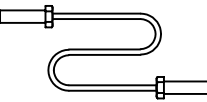
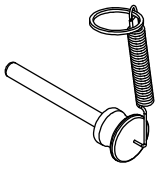
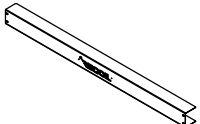
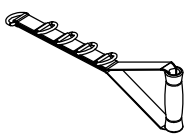
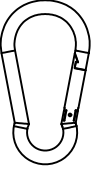
PARTS LIST

A1 Left Base 1PC 	A2 Right Base 1PC 	A3 Front Base 1PC 	A4 Connection 1PC 	A5 Back Base 1PC 
A6 Column 1PC 	A7 Sliding Sleeve 1PC 	A8 Anti-gangplank 2PCS 	A9 Step Threaded Post 1PC 	A10 80 Pulley 4PCS 
B1 Upper Beam Components 1PC 	B2 Buffer Pad 2PCS 	B3 Weight Sheet 14PCS 	B4 Weight Sheet(Top) 1PC 	B5 Guide Rod 2PCS 
B6 Fixed Plate 1PC 	B7 Cable A 1PC 	B8 Pulley Seat 1PC 	B9 Cable B 1PC 	B10 Weight Stack Pin 1PC 
C1 Protective Cover 2PCS 	C2 Cable Handle 2PCS 	C3 Clips 2PCS 		

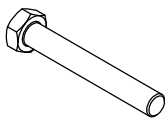
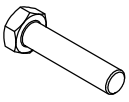
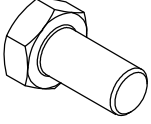
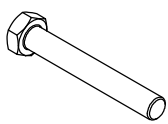
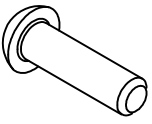
HARDWARE LIST

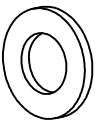
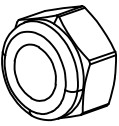
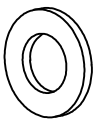
1 Bolt(M10 × 70) 12PCS 	2 Bolt(M10 × 45) 4PCS 	3 Bolt(M10 × 20) 1PC 	4 Bolt(M10 × 75) 4PCS 	5 Bolt (M10 × 35) 2PCS 
6 Bolt (M8 × 10) 8PCS 	7 Washer (M8) 8PCS 	8 Lucknut(M10) 16PCS 	9 Washer(M10) 37PCS 	

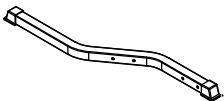
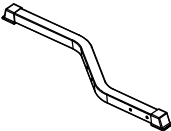
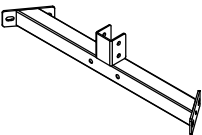
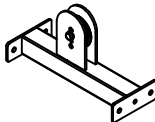
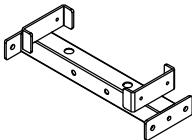
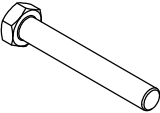
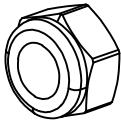
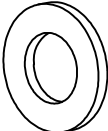

STEP 1:

A1 Left Base 1PC 	A2 Right Base 1PC 	A3 Front Base 1PC 	A4 Connection 1PC 	A5 Back Base 1PC 
1 Bolt(M10 x 70) 12PCS 	8 Locknut(M10) 12PCS 	9 Washer(M10) 24PCS 		

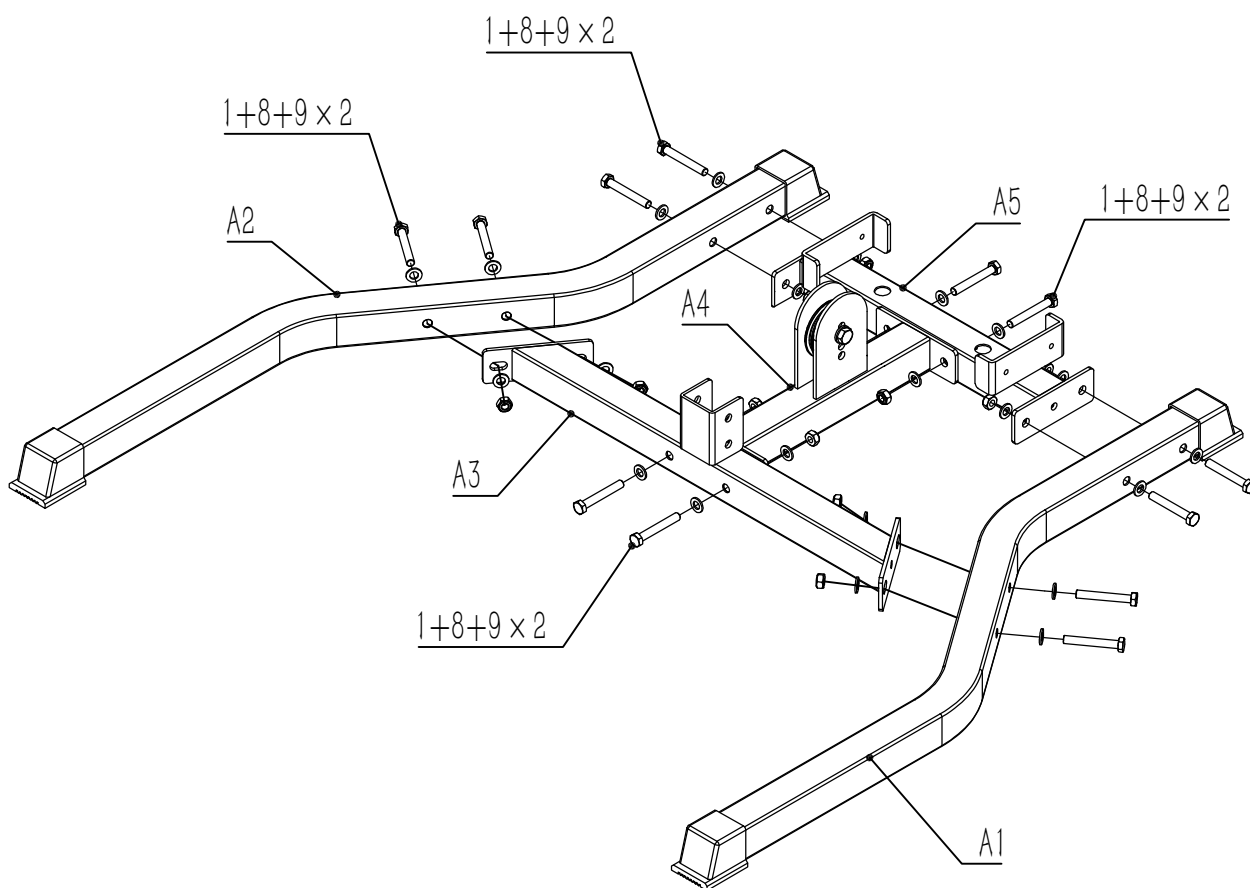
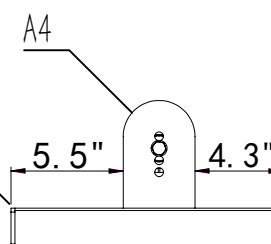
The longer end is facing forward

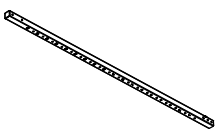

STEP 2:

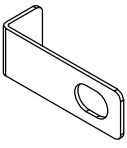
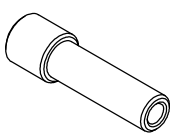
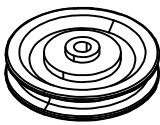
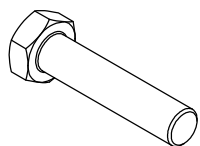
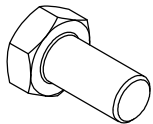
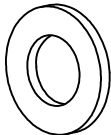
<p>A6 Column 1PC</p> 	<p>A7 Sliding Sleeve 1PC</p> 	<p>A8 Anti-gangplank 1PC</p> 	<p>A9 Step Threaded Post 1PC</p> 	<p>A10 80 Pulley 1PC</p> 
<p>2 Bolt(M10 x 45) 1PC</p> 	<p>3 Bolt(M10 x 20) 1PC</p> 	<p>9 Washer(M10) 2PCS</p> 		

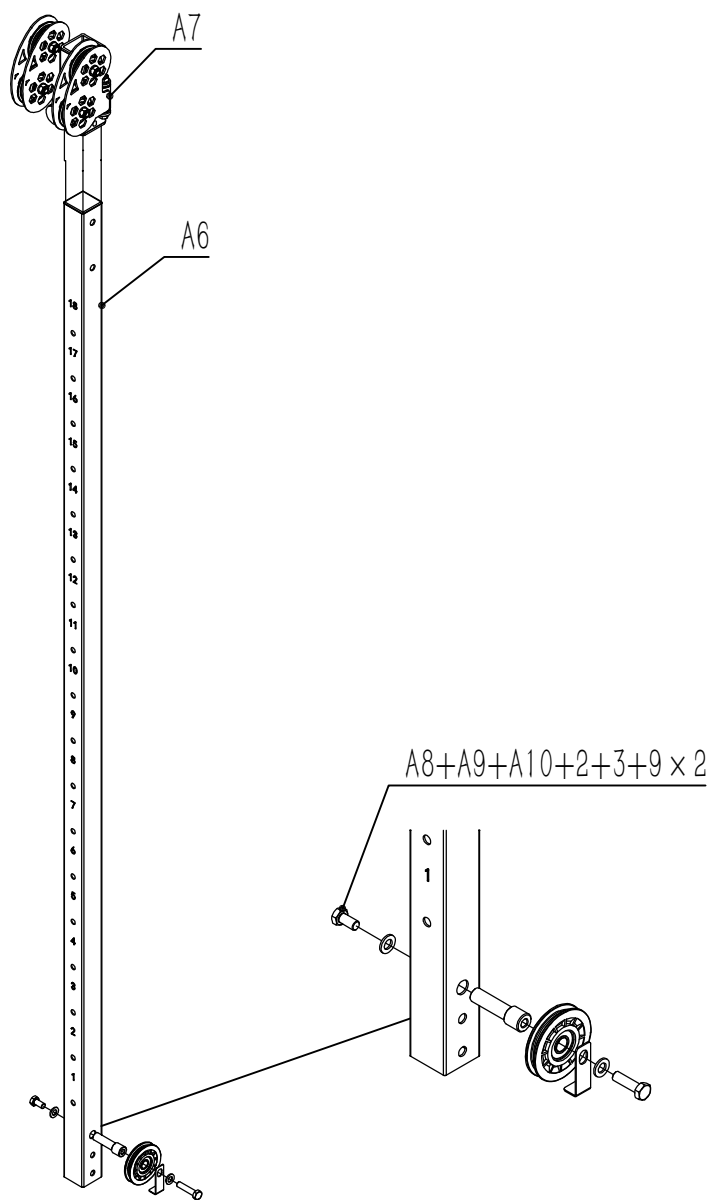

STEP3.

STEP2

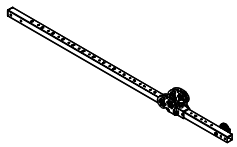

4 Bolt(M10 x 75)
2PCS

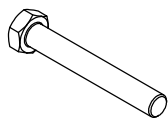

8 Lucknut(M10)
2PCS

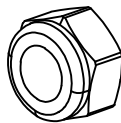

9 Washer(M10)
4PCS



STEP2

4+8+9 x 2

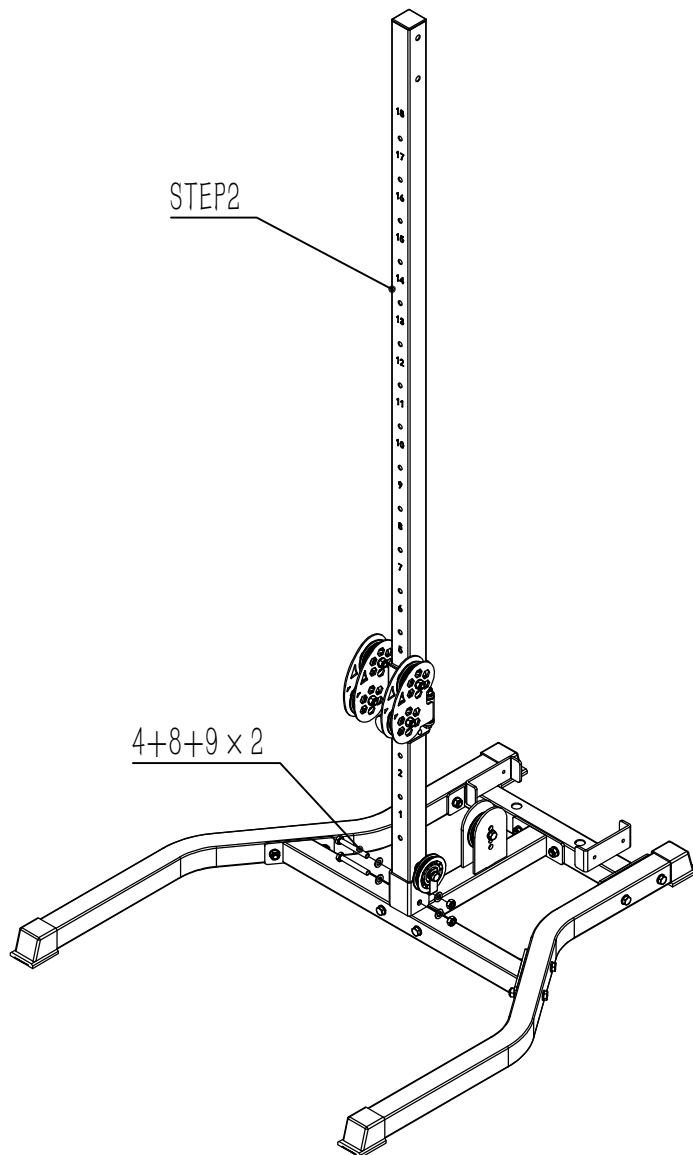

STEP4:

B1 Upper Beam Components
1PC

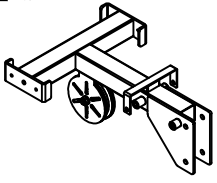

A10 80 Pulley
3PCS



A8 Anti-gangplank
1PC

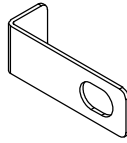

2 Bolt(M10 x 45)
3PCS

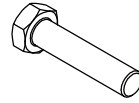

9 Washer(M10)
3PCS

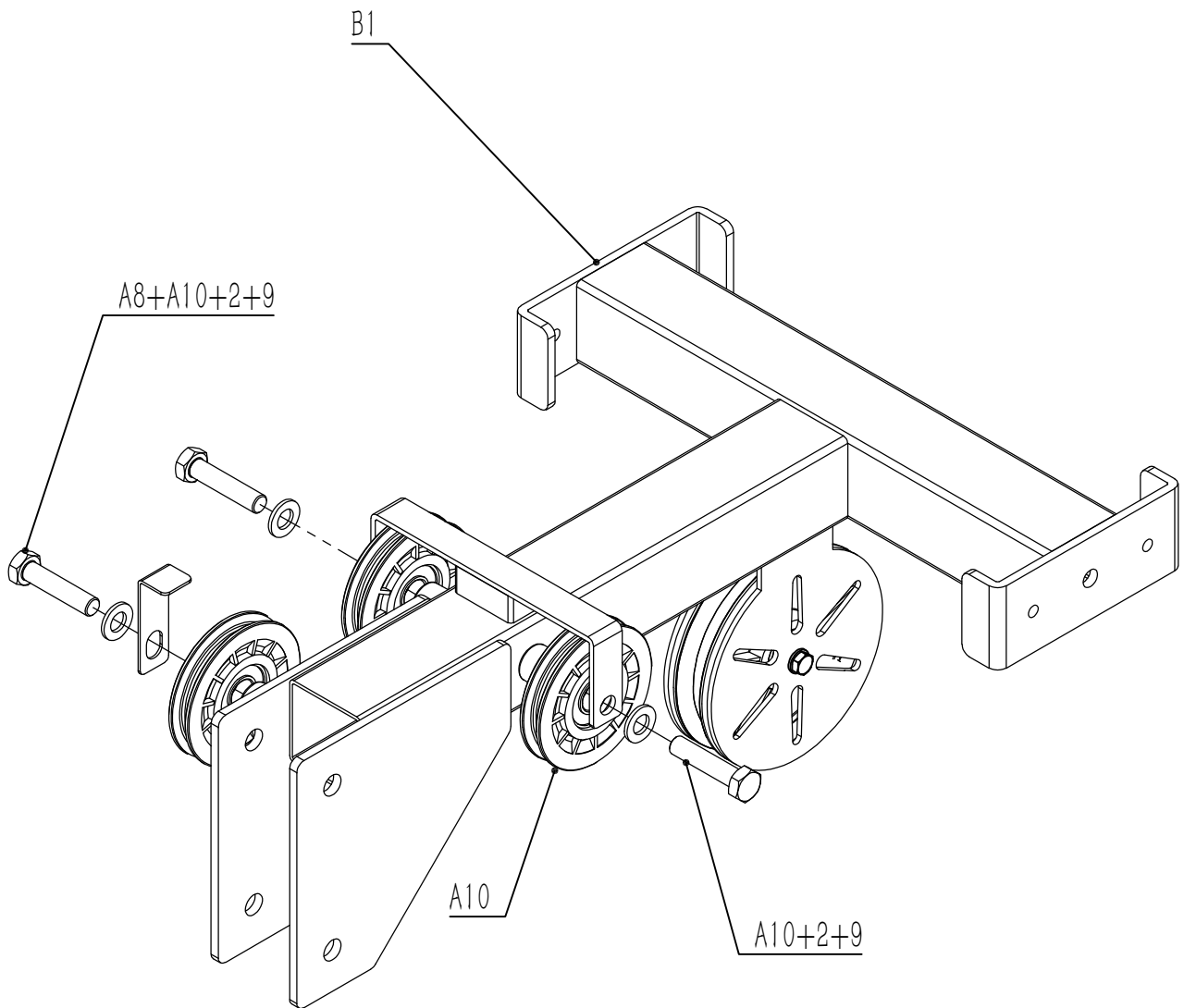
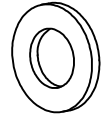

STEP5:

B2 Buffer Pad
2PCS

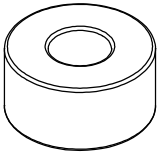

B3 Weight Sheet
14PCS

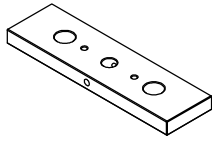

B4 Weight Sheet(Top)
1PC

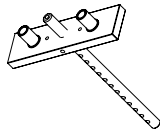

B5 Guide Rod
2PCS

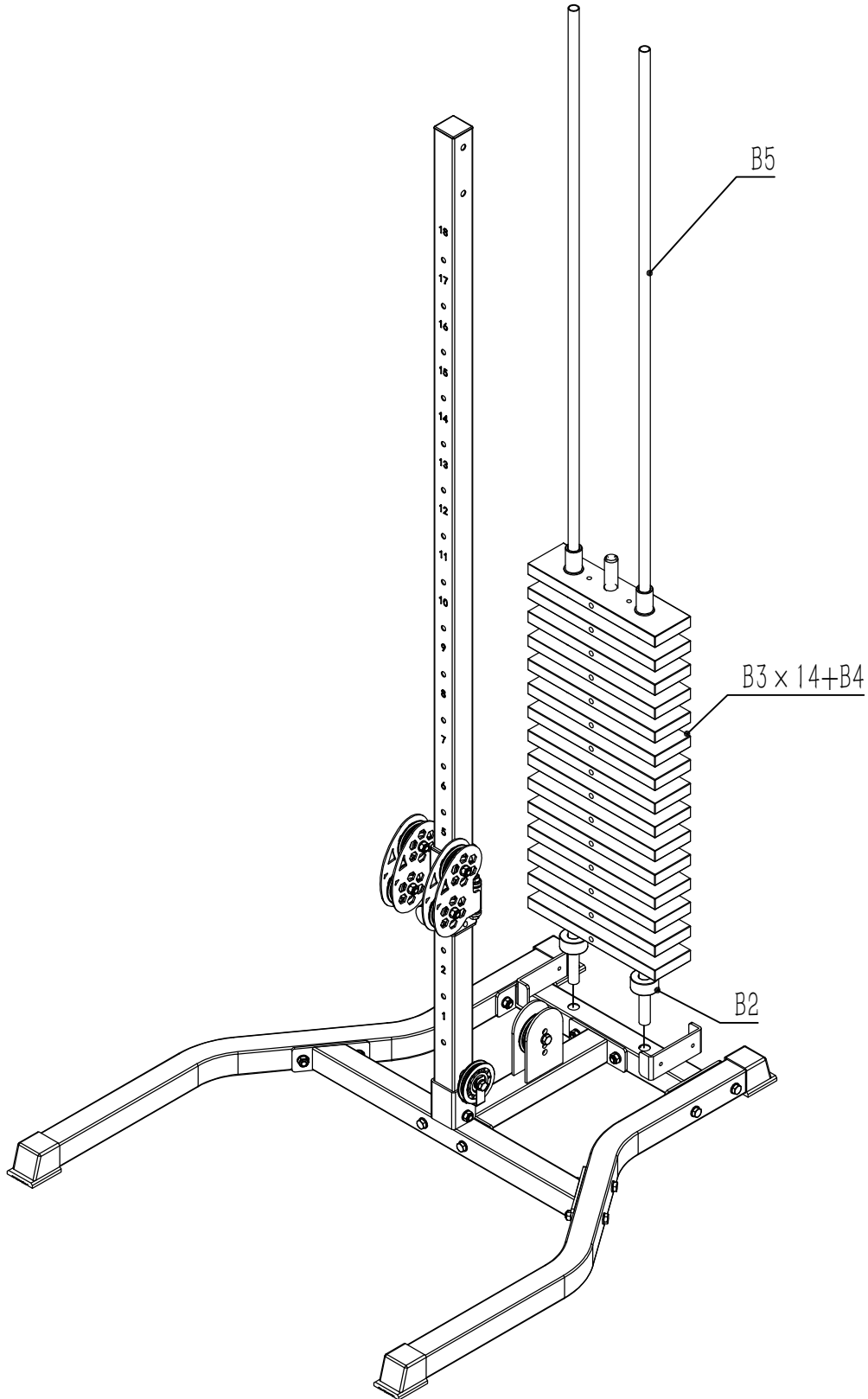
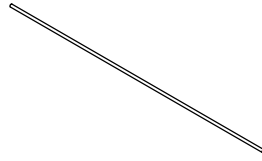

STEP6:

STEP4
1PC

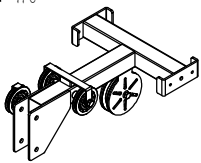

B6 Fixed Plate
1PC

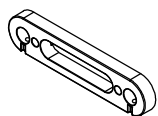

5 Bolt (M10 x 35)
2PCS

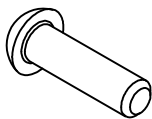

4 Bolt(M10 x 75)
2PCS

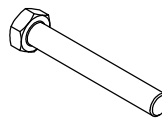

8 Locknut(M10)
2PCS

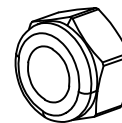

9 Washer(M10)
4PCS

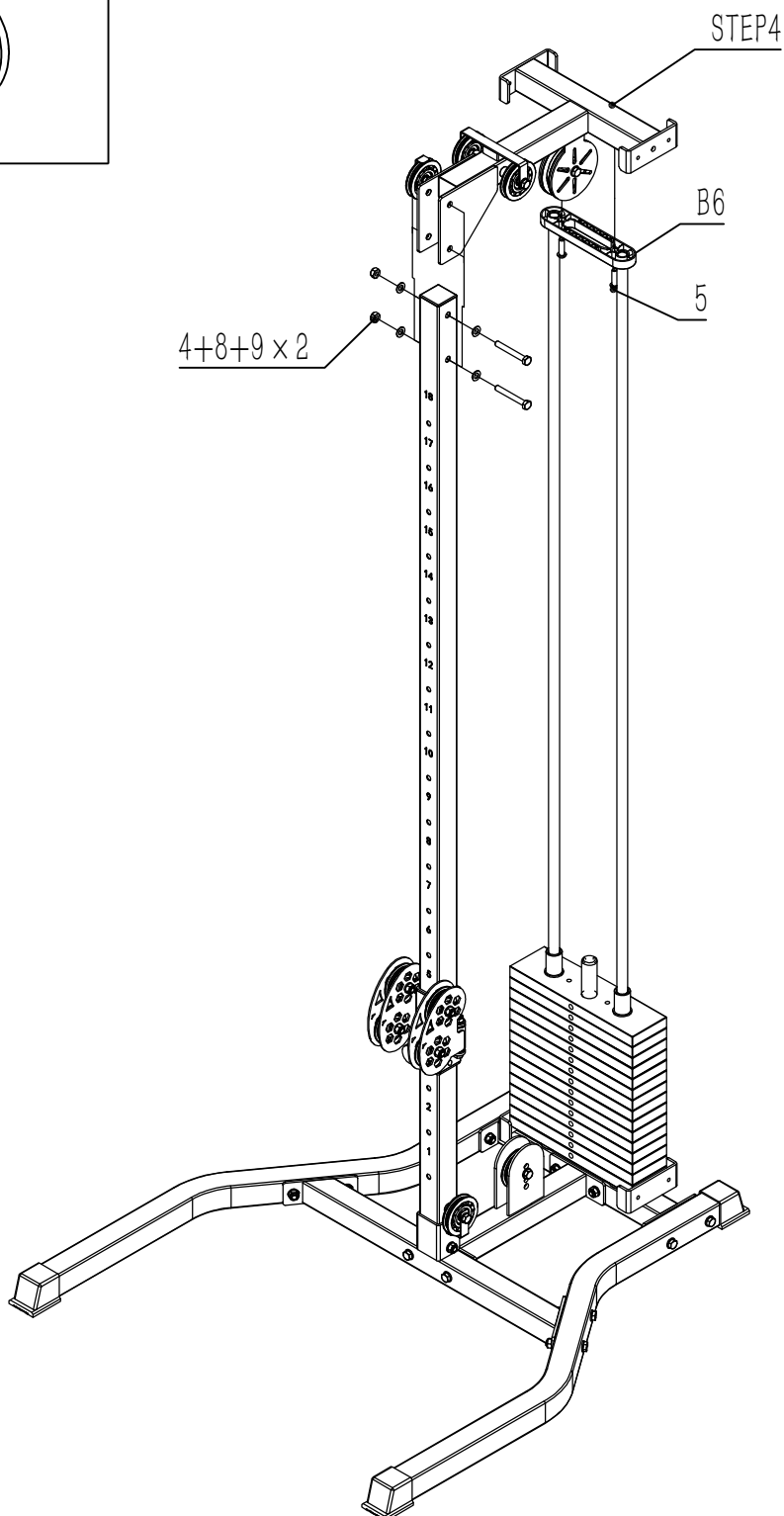
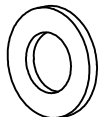

STEP 7:

B7 Cable A
1PC

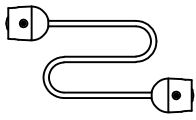

B8 Pulley Seat
1PC

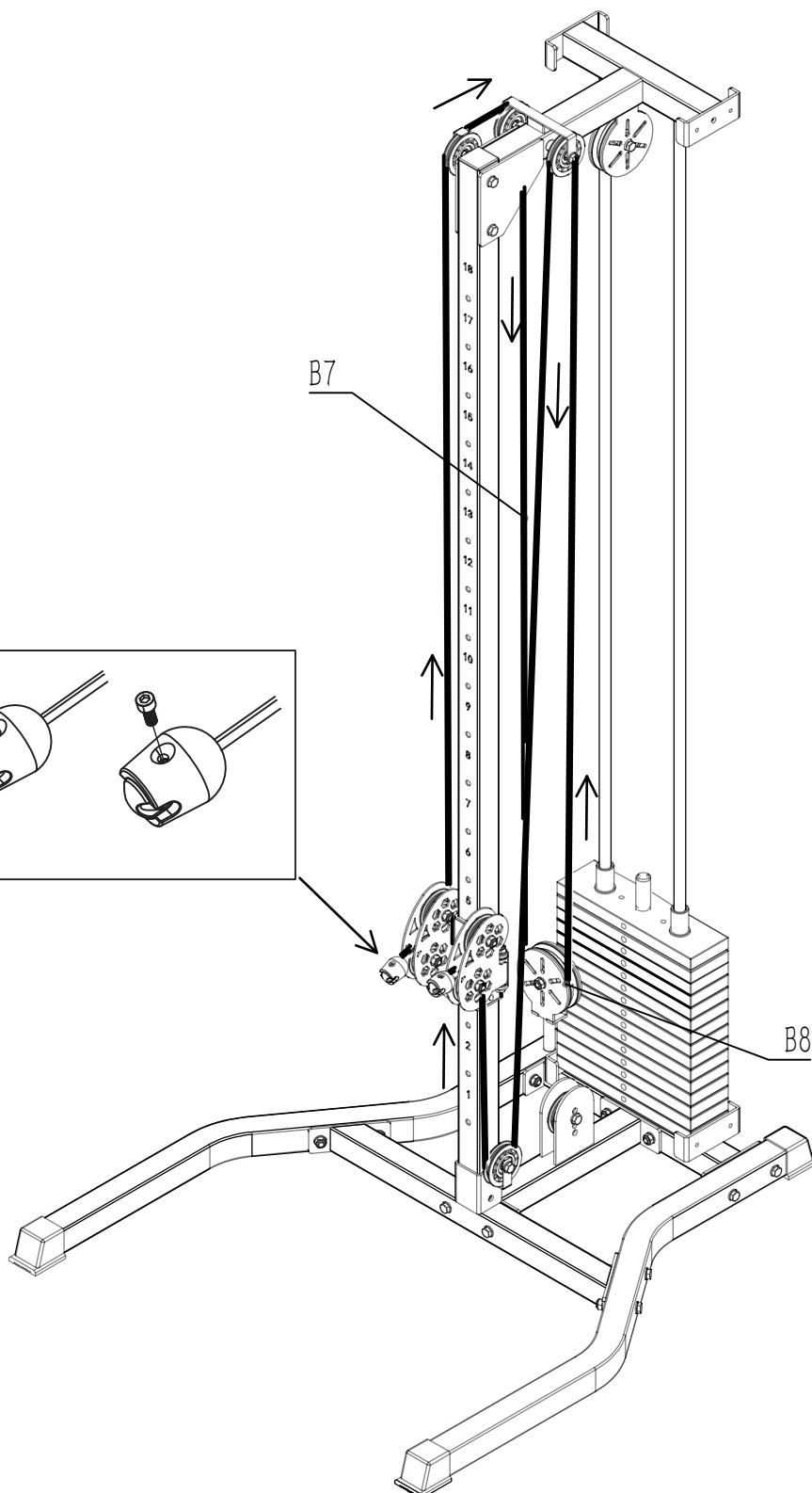
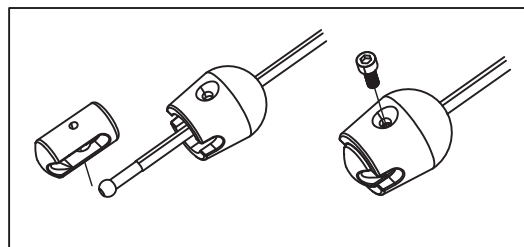
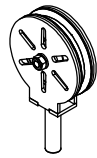

STEP 8:

B9 Cable B
1PC

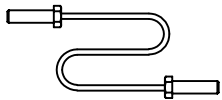

B10 Weight Stack Pin
1PC

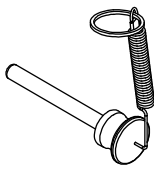

Lock here to adjust cable length



Lock here to adjust cable length

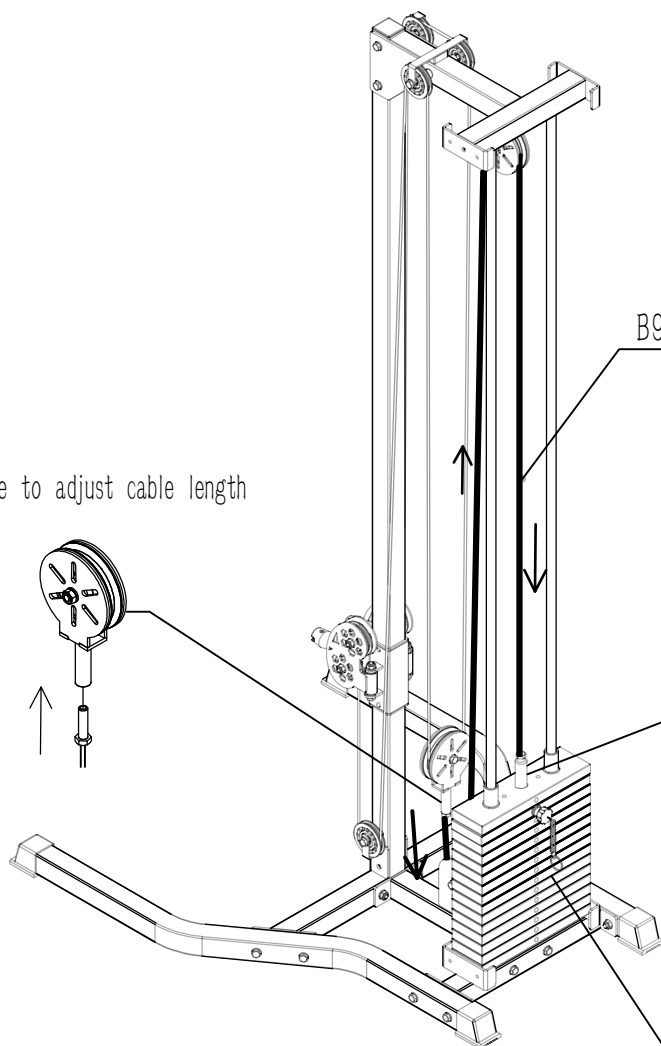
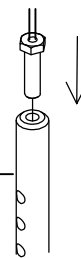

Insert to select gear

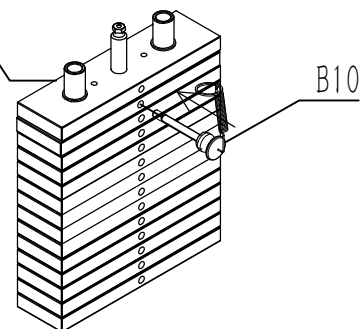

STEP 9:

C1 Protective Cover
2PCS

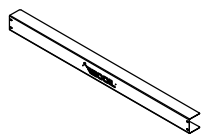

6 Bolt (M8 x 10)
8PCS



7 Washer (M8)
8PCS

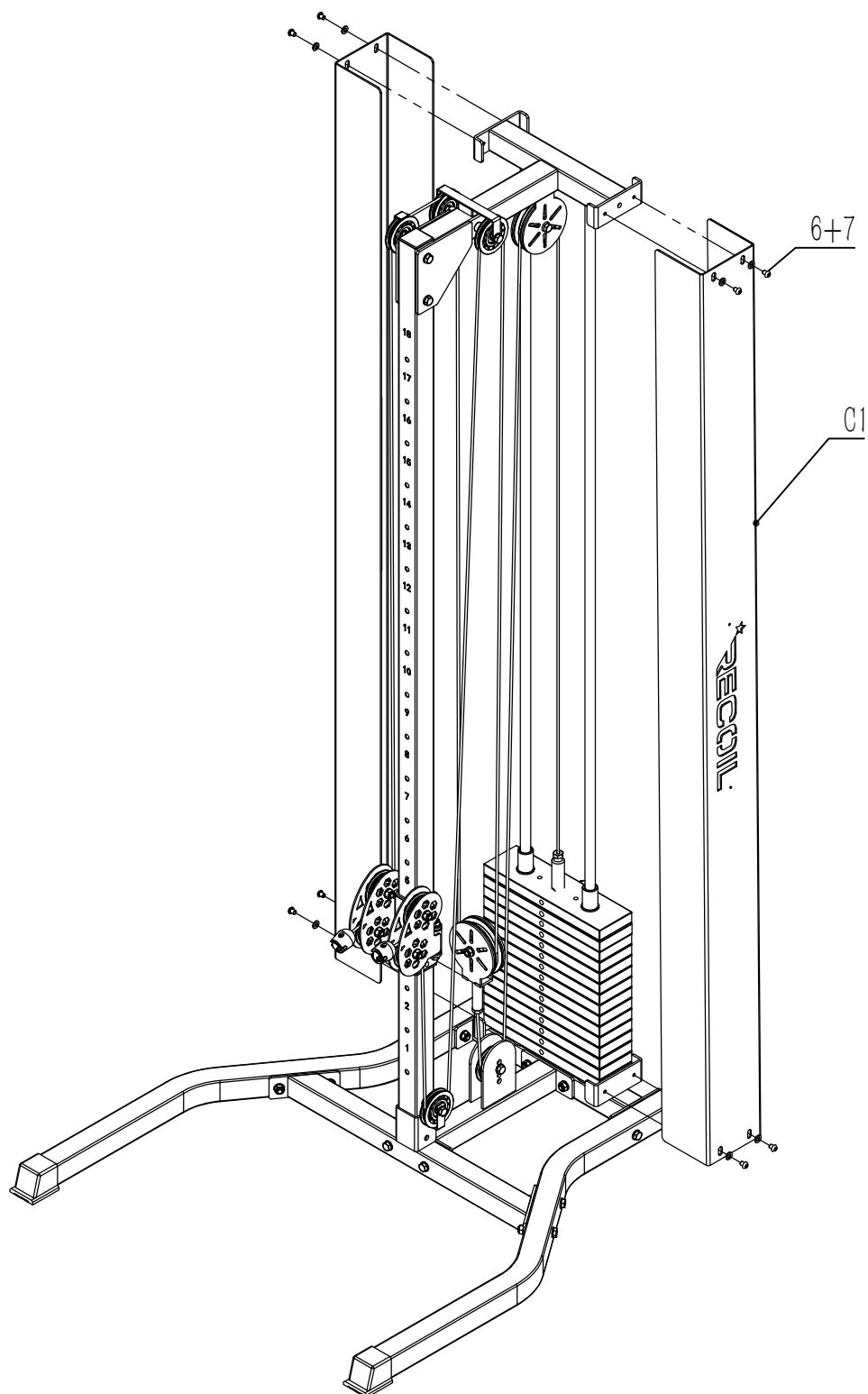
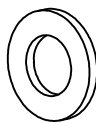

STEP 10:

C2 Cable Handle
2PCS

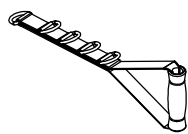

C3 Clips
2PCS

