

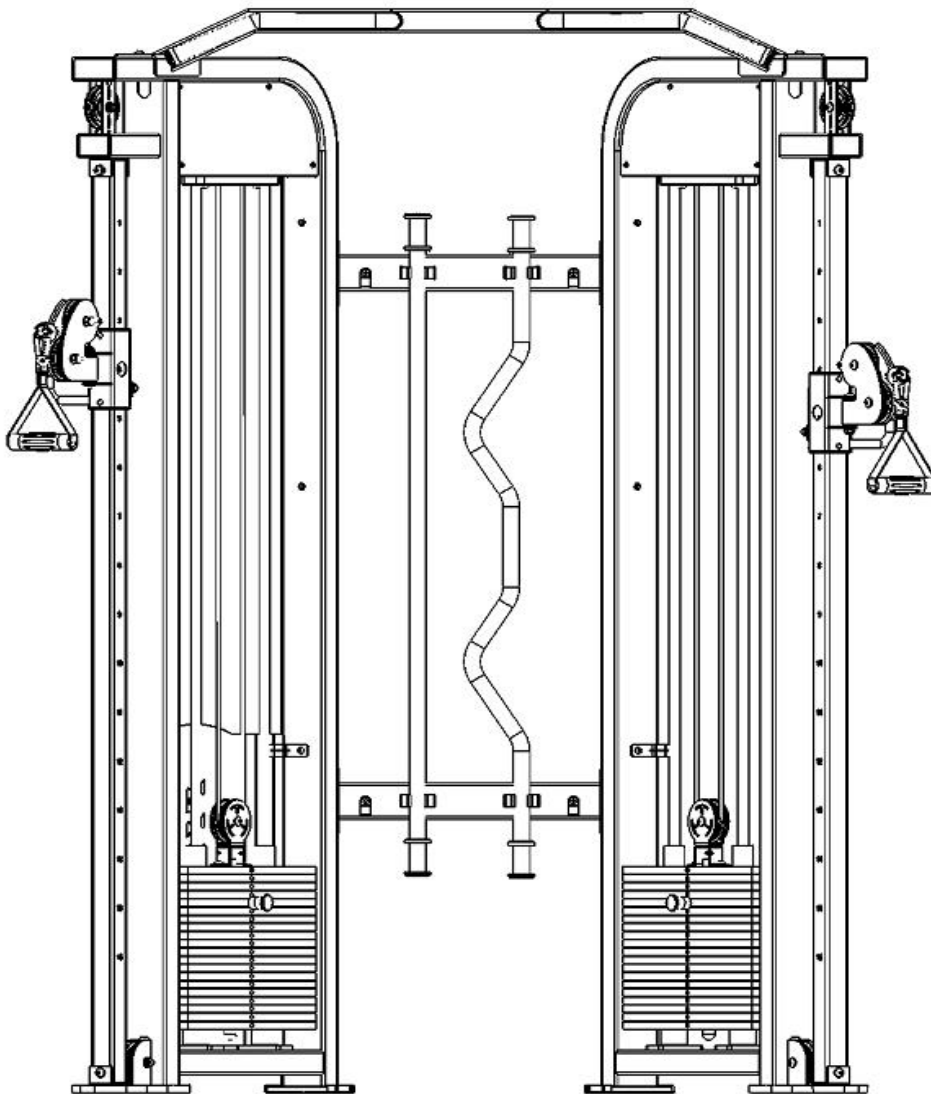

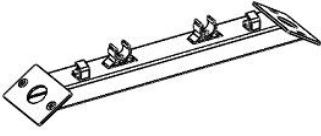

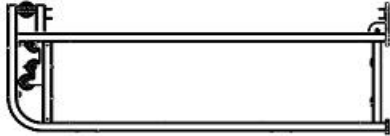

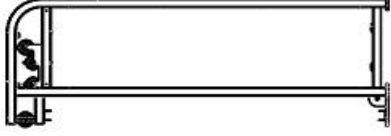



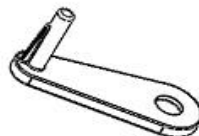



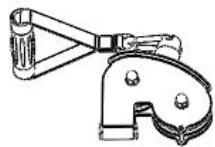
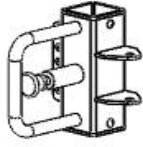

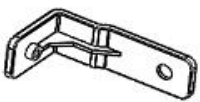
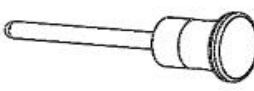
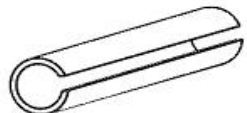

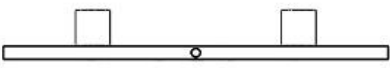

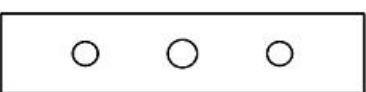
G5090 Functional Trainer

Installation Standard Instructions

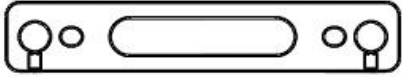

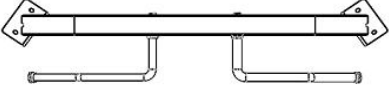



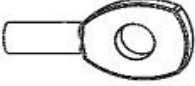

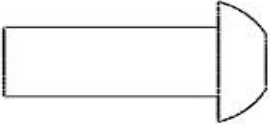
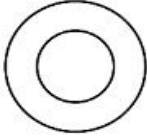
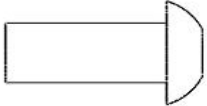
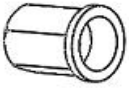

Parts list (Individually packaged)

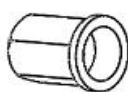
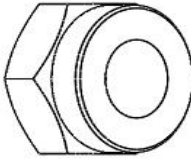
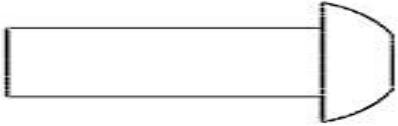
					
No.1	Connection welding group*2pcs	No.2	Small door welding set right*1pc	No.3	Small door welding set left*1pc
					
No.6	Φ90 Pulley*16pcs	No.7	Pulley ferrule*6pcs	No.8	50*75 Pipe stopper*2pcs
					
No.9	50*100 Pipe stopper*2pcs	No.10	Ground right*1pc	No.11	Ground Cover*2pcs
					
No.12	Cable crossover pulley Set*2pcs	No.13	Slip-on set*2pcs	No.14	Stainless Steel Tubing*2pcs
					
No.22	Small mounting bracket*8pcs	No.23	No.41 New pulling pin*2pcs	No.24	C-shaped cotter pin*2pcs
					
No.25	Guide Rod*4pcs	No.26	Weighted rubber column*2pcs	No.27	Weight stack head piece*2pcs
					
No.28	Small door pulley set*2pcs	No.29	Weight Stack*38pcs	No.30	New 19-hole weight adjustment rod*2pcs

					
No.31	New optical shaft fixing plate*2pcs	No.32	Label board*4pcs	No.33	Small door guard*2pcs
					
No.34	Upper connection assembly*1pc	No.35	A Push for connection group*1pc	No.36	B Push for connection group*1pc
					
No.43	Ground left*1pc	No.44	Cable*4pcs	No.45	Cable fixing flat head*2pcs

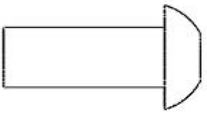
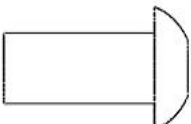
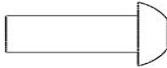
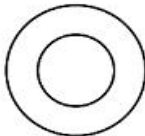
Blister Pack Screws List

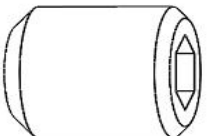
					
A	M10*30 Flat round head screw*12pcs	B	Φ10 Flat gasket*62pcs	C	M8*25 Flat round head screw*8pcs
					
D	M8 External hexagon rivet nut*24pcs	E	M10*45 Flat round head screw*14pcs	F	Snap Pin*4pcs
					
G	M10 Hexagonal rivet nut*12pcs	H	M10 Anti-loosening nut*20pcs	I	M10*50 Flat round head screw*2pcs
					
J	M10*80 Flat round head screw*2pcs	K	M10*70 Flat round head screw*4pcs	L	M10 Nut*4pcs
					
M	M8*20 Half round head screw*12pcs	N	M10*20 Flat round head screw*8pcs	O	M5*8 Cross recessed pan head screw*24pcs
					
P	Φ5 Gasket*24pcs	Q	M8*20 Flat countersunk head screw*2pcs	R	8*12 Set screw*4pcs

Assembly Steps

Step NO	Item NO	Name	Quantity	Item NO	Name	Quantity
1	No.1	Connection welding group	2	A	M10*30 Flat round head screw	8
	No.2	Small door welding set right	1	B	Φ10 Flat gasket	8
	No.3	Small door welding set left	1			

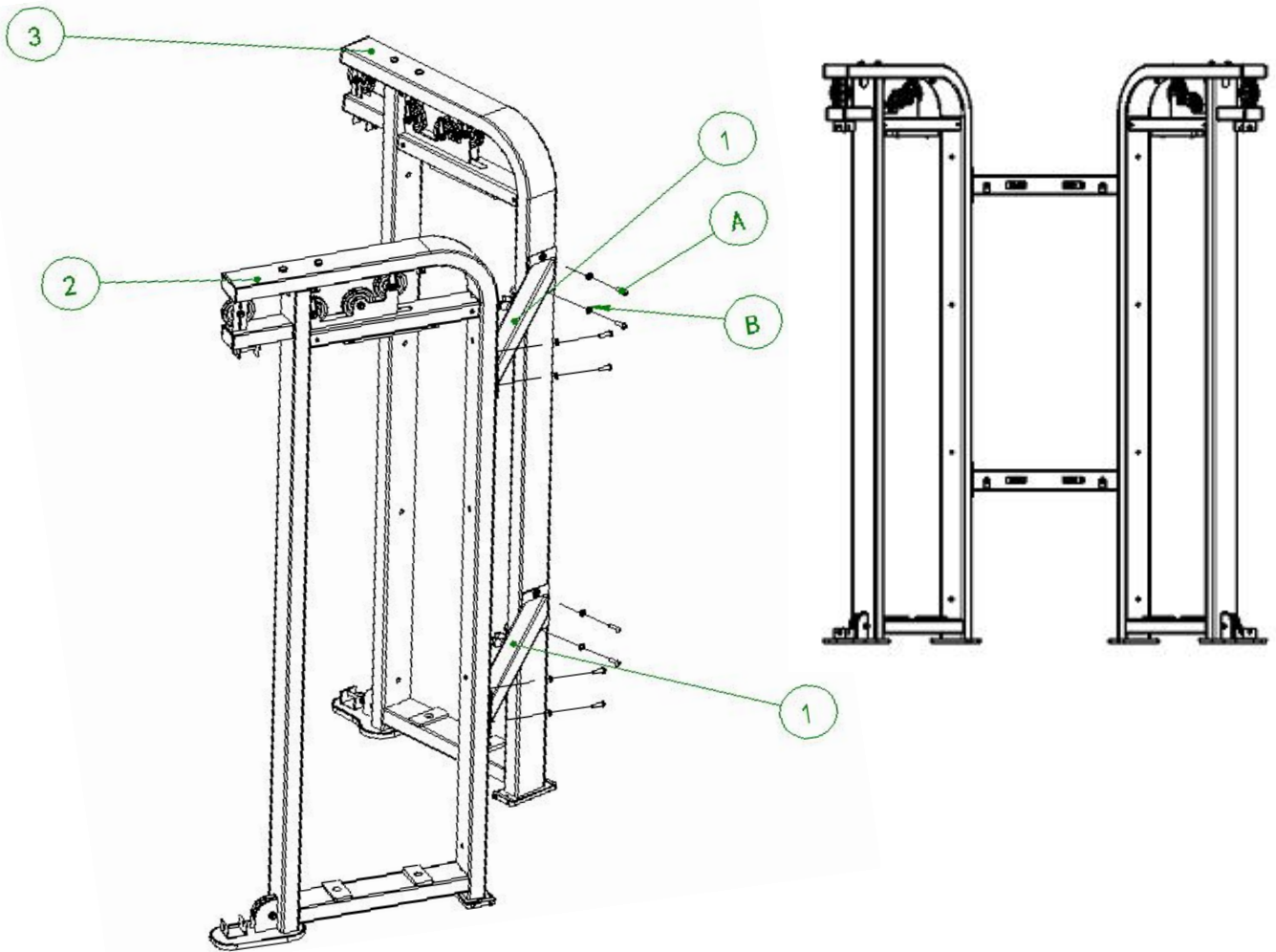

No.1 Connection welding group*2pcs

Step NO	Item NO	Name	Quantity	Item NO	Name	Quantity
	No.4	Snap bushing	2	C	M8*25 Flat round head screws	4
	No.5	Plastic hook	2	D	M8 Hexagon rivet nut	4

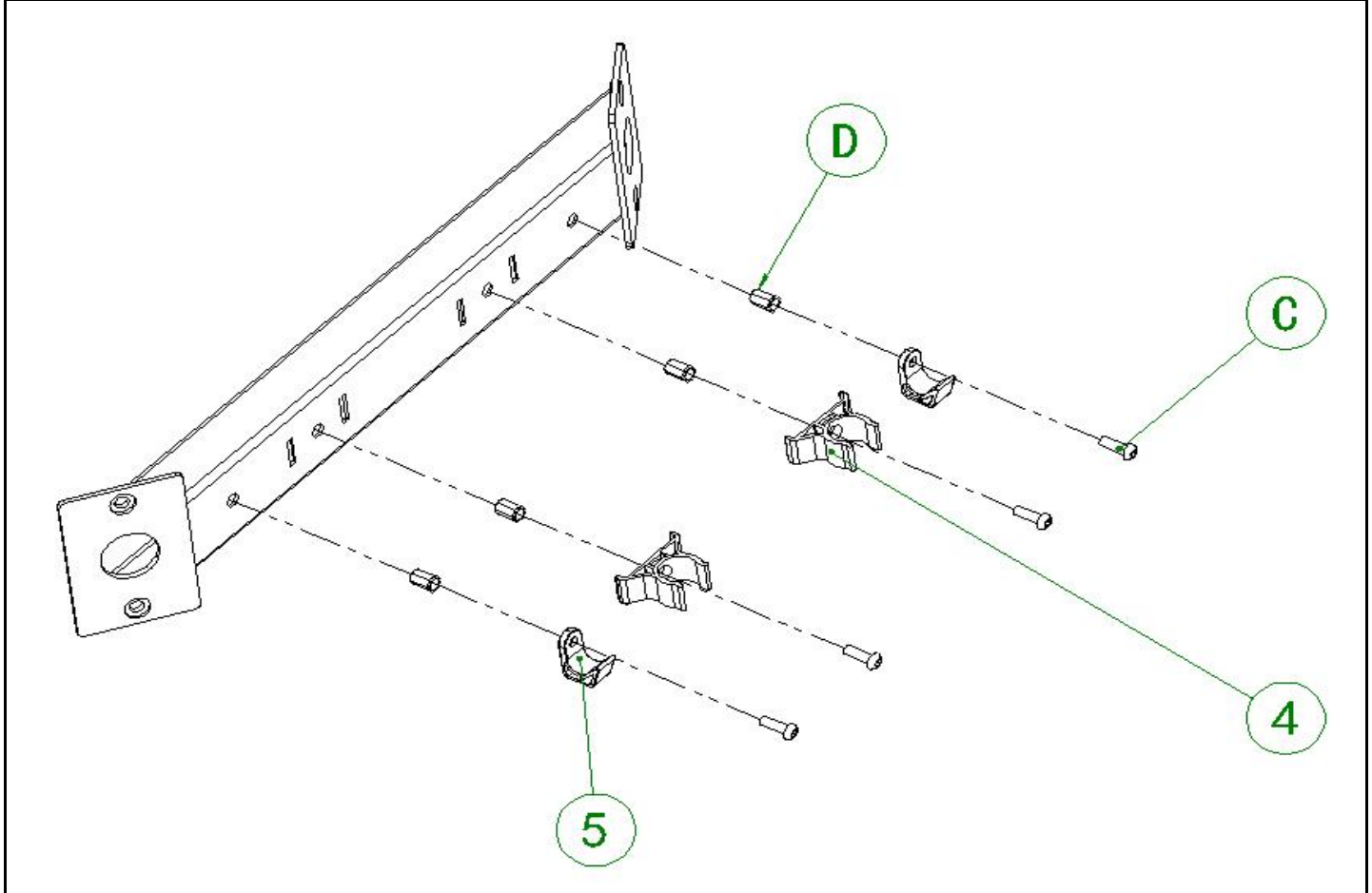

No.2 Small door welding set right*1 pc

Step NO	Item NO	Name	Quantity	Item NO	Name	Quantity
	No.6	Φ90 Pulley	5	D	M8 External hexagon rivet nut	8
	No.7	Pulley ferrules	3	E	M10*45 Flat round head screw	4
	No.8	50*75 Pipe stopper	1	F	Snap Pin	1
	No.9	50*100 Pipe stopper	1	G	M10 Hexagonal rivet nut	4
	No.10	Ground right	1	H	M10 Anti-loosening nut	5
	No.11	Ground Cover	1	I	M10*50 Flat round head screw	1
	B	Φ10 Flat gasket	7			

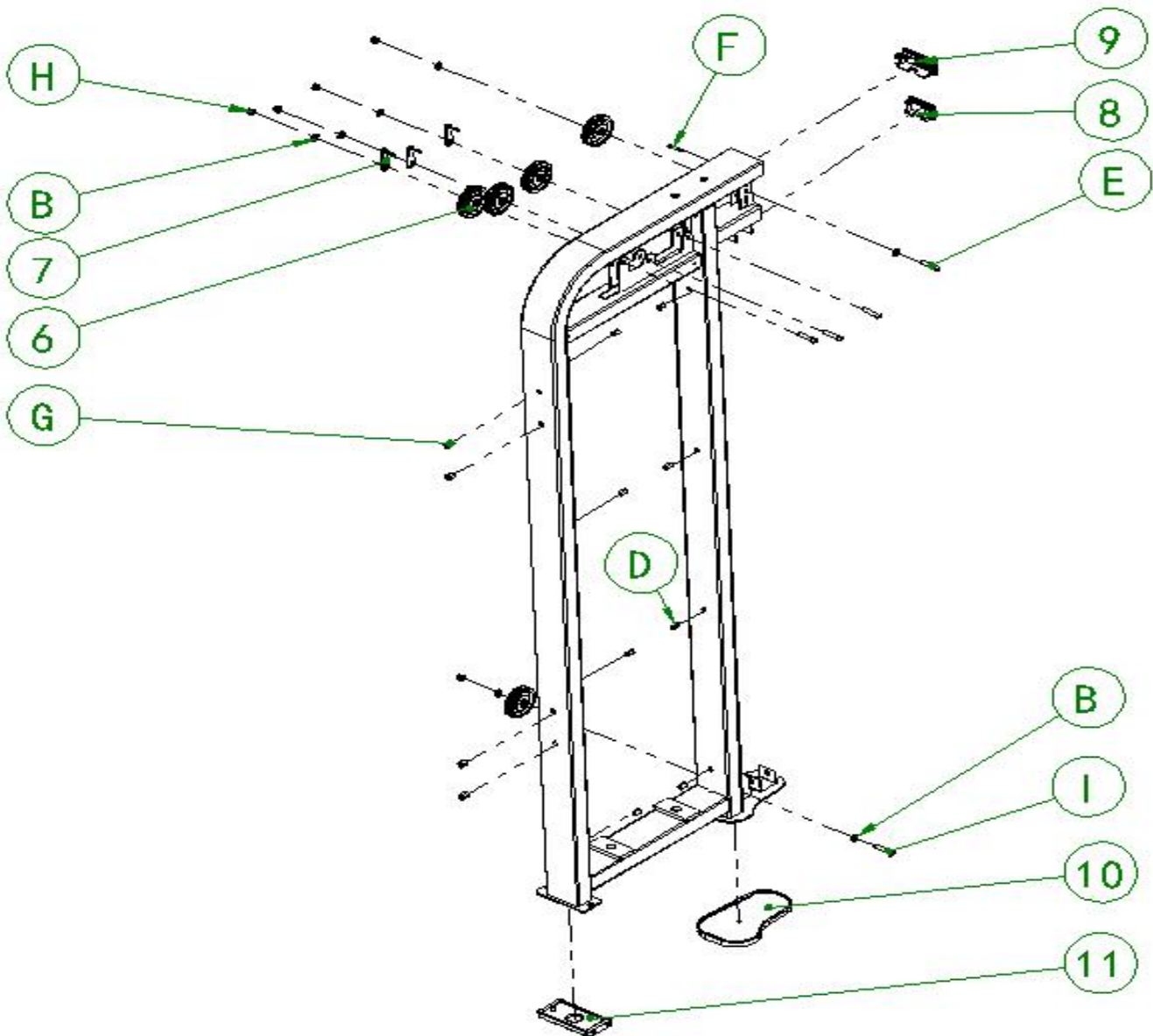

No.3 Small door welding set Left*1pc

Step NO	Item NO	Name	Quantity	Item NO	Name	Quantity
	No.6	Φ90 Pulley	5	D	M8 External hexagon rivet nut	8
	No.7	Pulley ferrules	3	E	M10*45 Flat round head screw	4
	No.8	50*75 Pipe stopper	1	F	Snap Pin	1
	No.9	50*100 Pipe stopper	1	G	M10 Hexagonal rivet nut	4
	No.10	Ground right	1	H	M10 Anti-loosening nut	5
	No.11	Ground Cover	1	I	M10*50 Flat round head screw	1
	B	Φ10 Flat gasket	7			

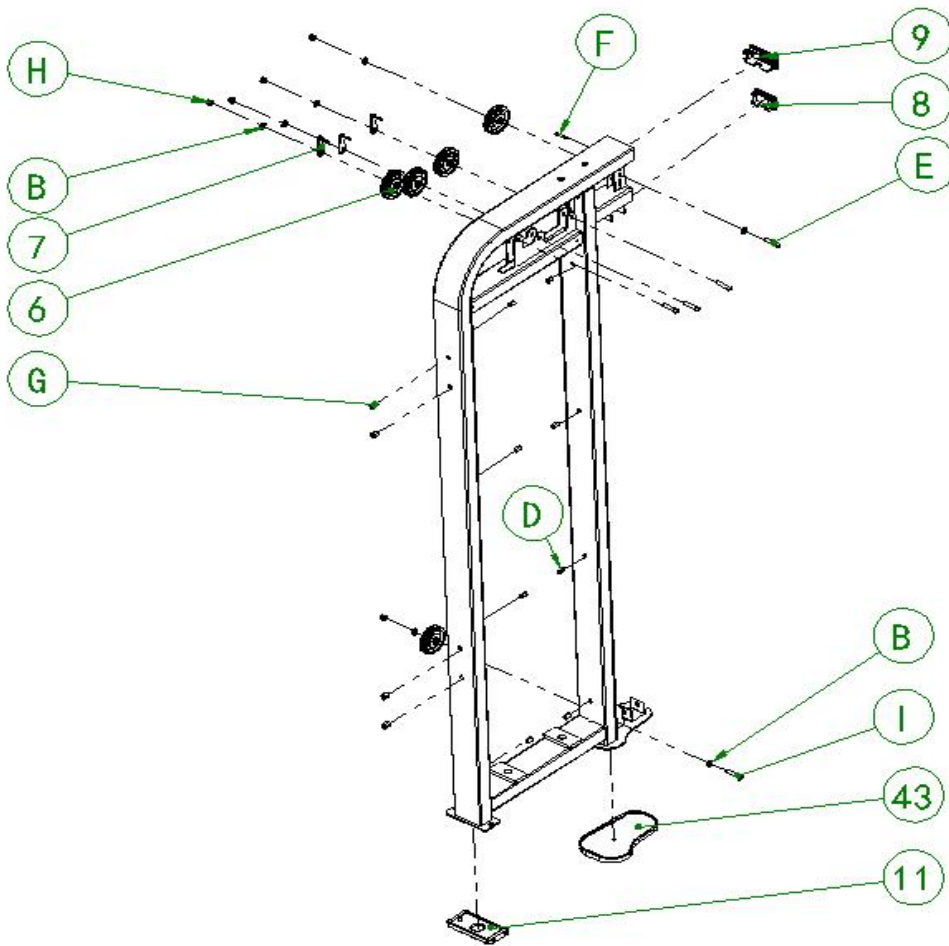

Assembly Steps

Step NO	Item NO	Name	Quantity	Item NO	Name	Quantity
2	No.12	Cable crossover pulley Set	2	H	M10 Anti-loosening nut	6
	No.13	Slip-on set	2	K	M10*70 Flat round head screw	4
	No.14	Stainless Steel Tubing	2			
	B	Φ10 Flat gasket	12			

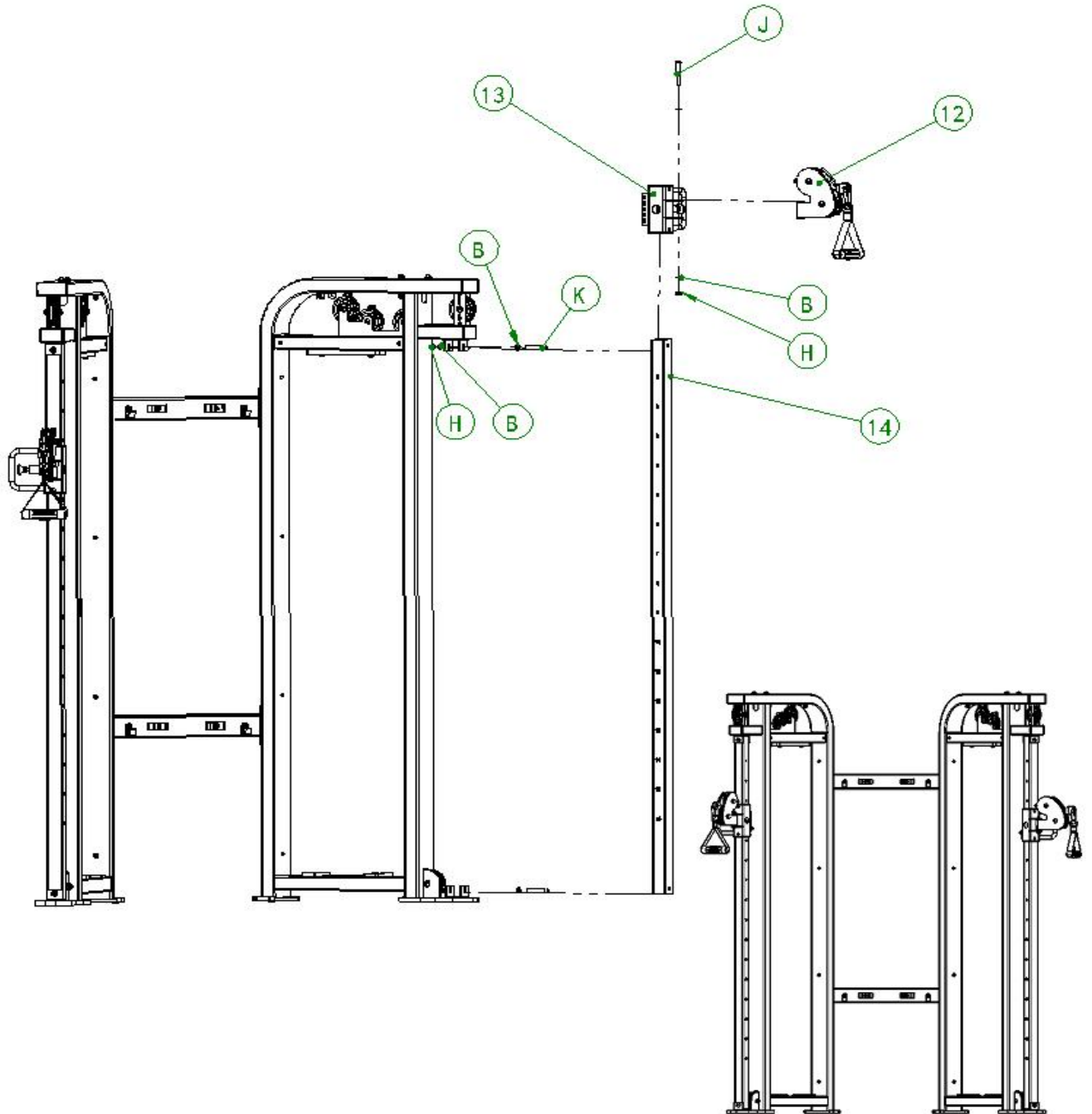

No.12 Cable crossover pulley Set*2pcs

Step NO	Item NO	Name	Quantity	Item NO	Name	Quantity
	No.6	Φ90 Pulley	2	B	Φ10 Flat gasket	4
	No.15	Low-level handle	1	F	Snap Pin	1
	No.16	Steel cable head	1	L	M10 Nut	2
	No.17	Safety hook	1	E	M10*45 Flat round head screw	2
	No.18	Cable crossover nylon cover	2			

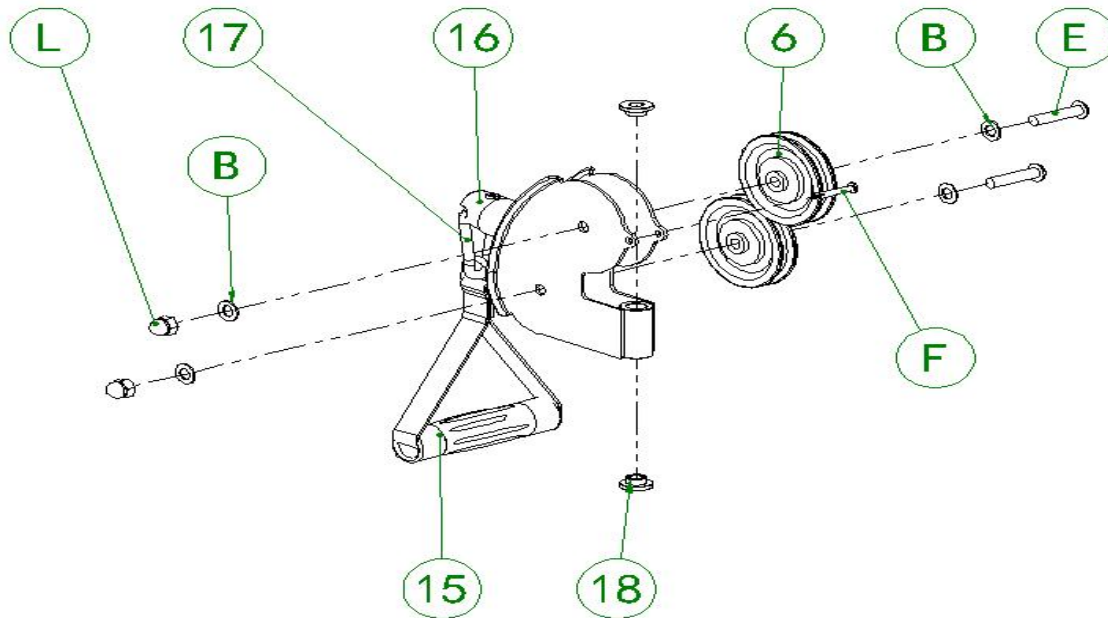

No.13 Slip-on set*2pcs

Step NO	Item NO	Name	Quantity	Item NO	Name	Quantity
	No.19	50*50 Pipe Sleeve	2	No.21	Aluminium pop pin	1
	No.20	Pins (galvanised)	1			

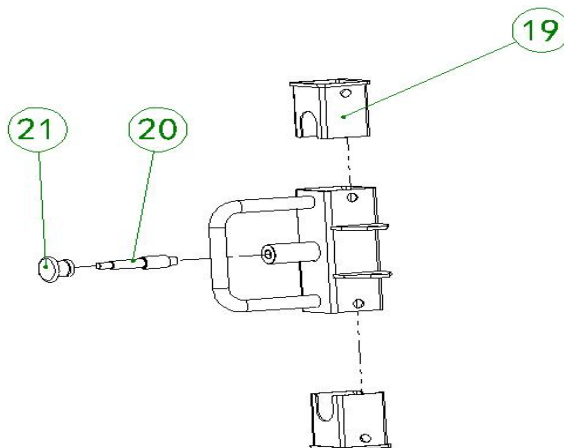

Assembly Steps

Step NO	Item NO	Name	Quantity	Item NO	Name	Quantity
3	No.22	Small mounting bracket	8	M	M8*20 Half round head screw	8

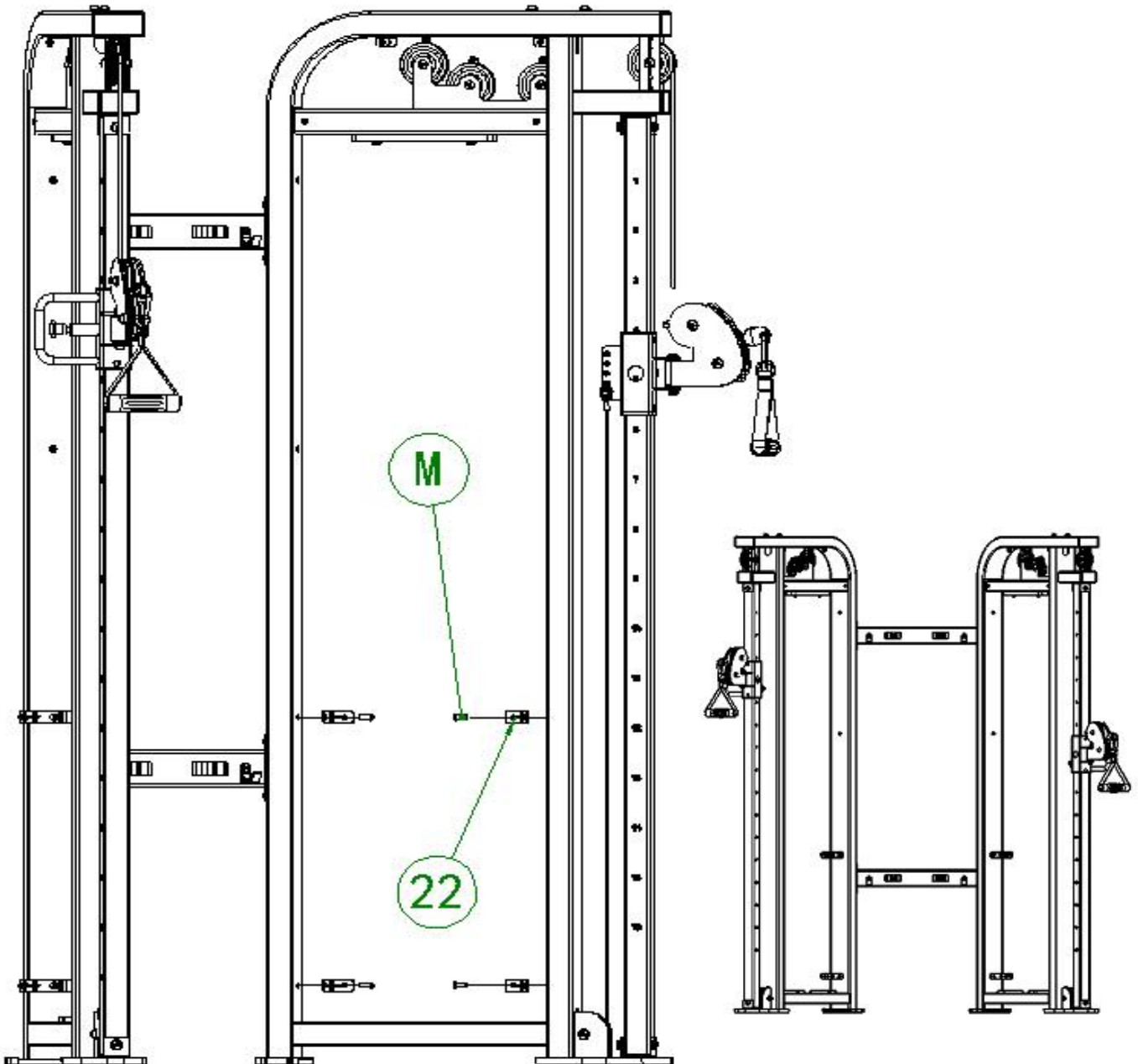

Assembly Steps

Step NO	Item NO	Name	Quantity	Item NO	Name	Quantity
4	No.23	No.41 New pulling pin	2	No.29	Weight Stack	38
	No.24	C-shaped cotter pin	2	No.30	New 19-hole weight adjustment rod	2
	No.25	Guide Rod	4	No.31	New optical shaft fixing plate	2
	No.26	Weighted rubber columns	4	A	M10*30 Flat round head screw	4
	No.27	Weight stack head piece	2	B	Φ10 Flat gasket	8
	No.28	Small door pulley set	2	N	M10*20 Flat round head screw	4
					R	8*12 Set screw

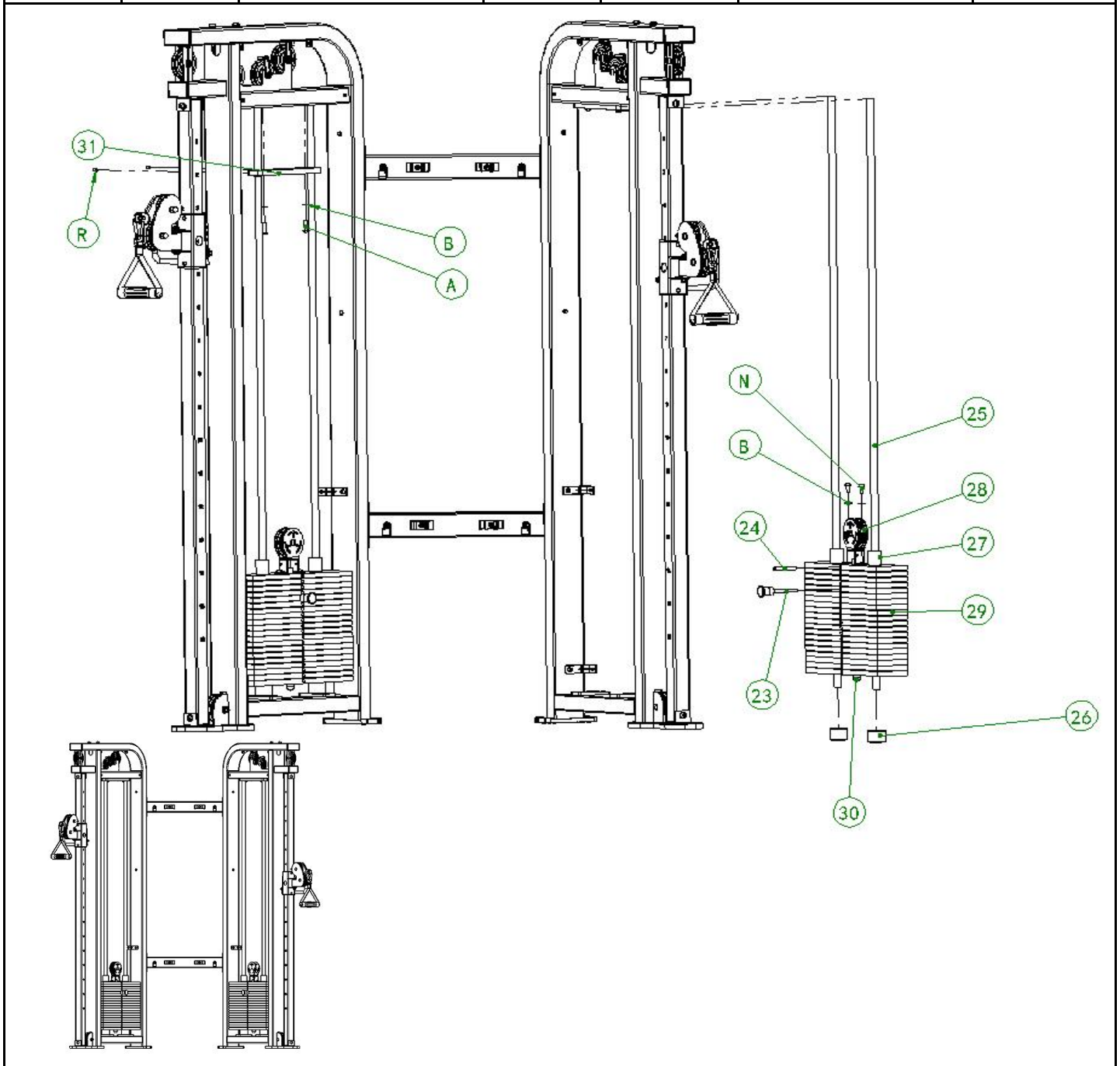

No.28 Small door pulley set*2pcs

Step NO	Item NO	Name	Quantity	Item NO	Name	Quantity
	E	M10*45 Flat round head screw	1	B	Φ10 Flat gasket	2
	H	M10 Anti-loosening nut	1	No.6	Φ90 Pulley	1

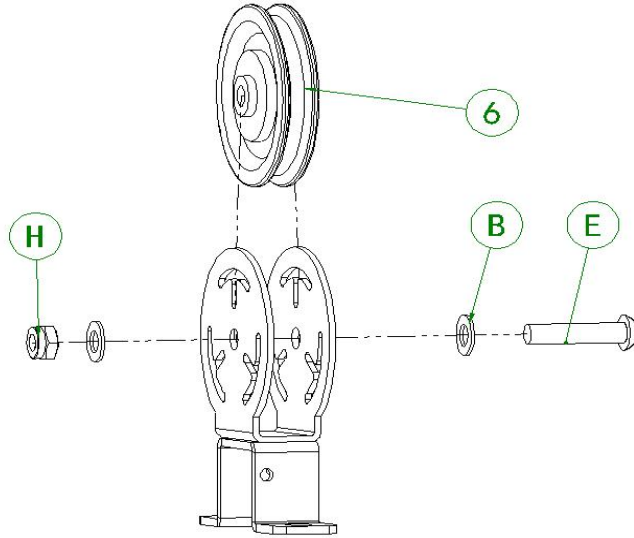

No.27 Weight stack head piece*2pcs

Step NO	Item NO	Name	Quantity	Item NO	Name	Quantity
	No.41	090 Counterweight guide bush	2	No.42	Long Weight stack head piece	1

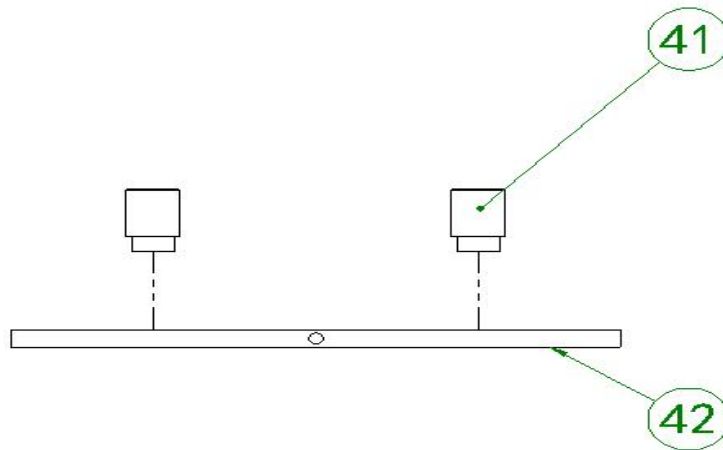

Assembly Steps

Step NO	Item NO	Name	Quantity	Item NO	Name	Quantity
5	B	Φ10 Flat gasket	4	S	M10*25 Flat round head screw	2
	H	M10 Anti-loosening nut	2	No.45	Cable fixing flat head	2

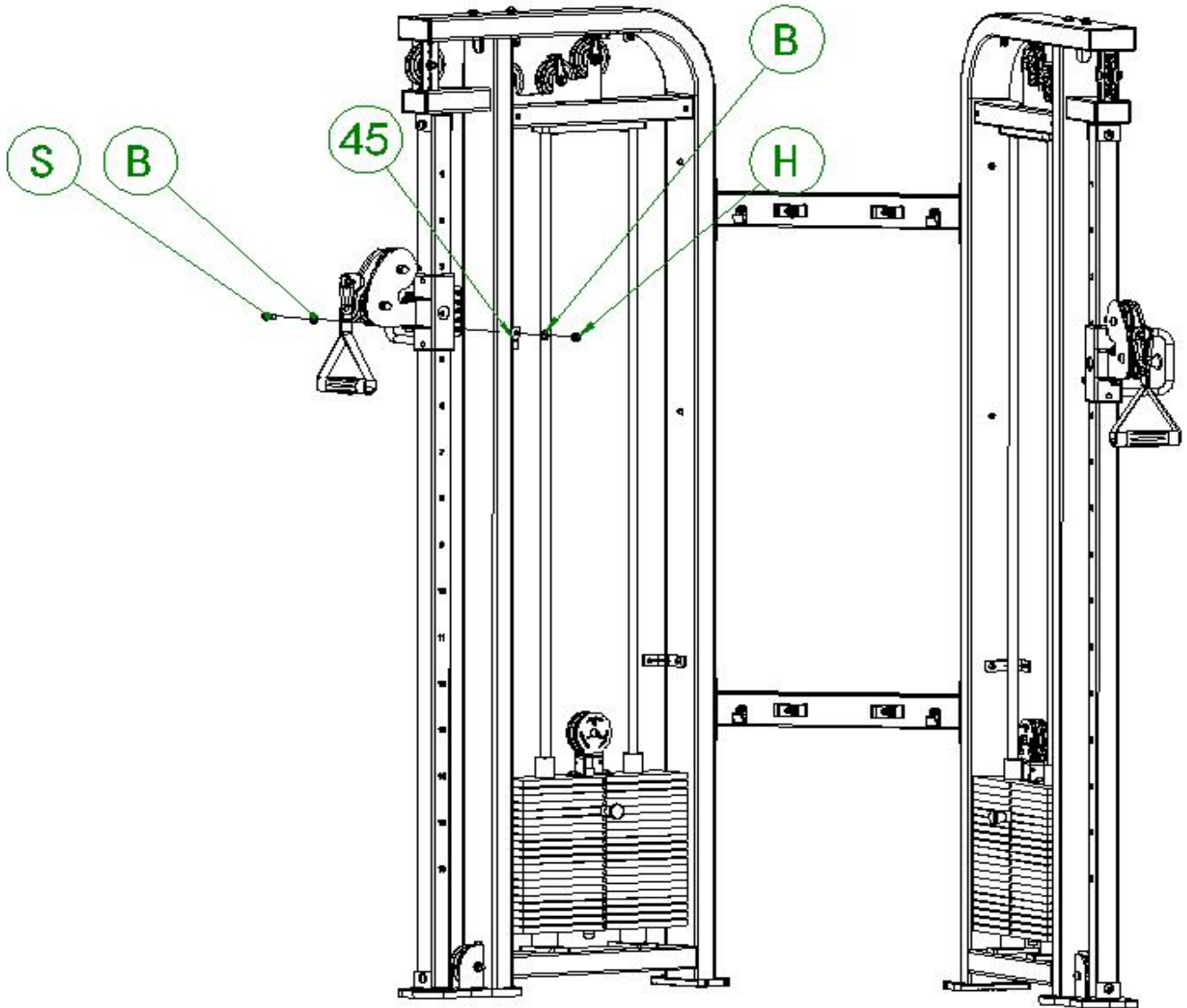

Assembly Steps

Step NO	Item NO	Name	Quantity	Item NO	Name	Quantity
6	No.44	Cable	4			

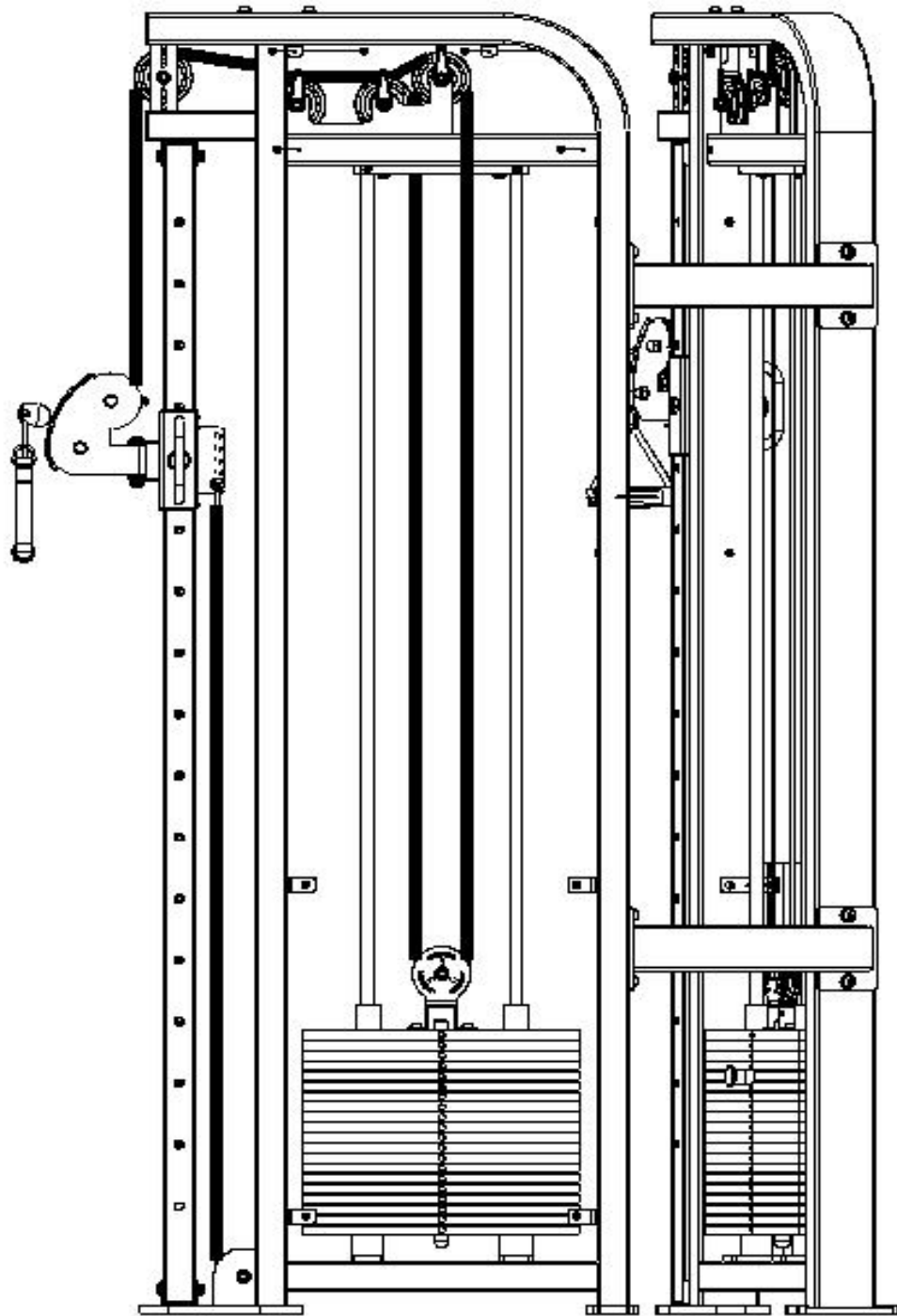

Wire rope alignment diagram

Assembly Steps

Step NO	Item NO	Name	Quantity	Item NO	Name	Quantity
7	32	Wire rope alignment diagram	2	O	M5*8 Cross recessed pan head screw	12
	33	Wire rope alignment diagram	1	P	Φ5 Gasket	12

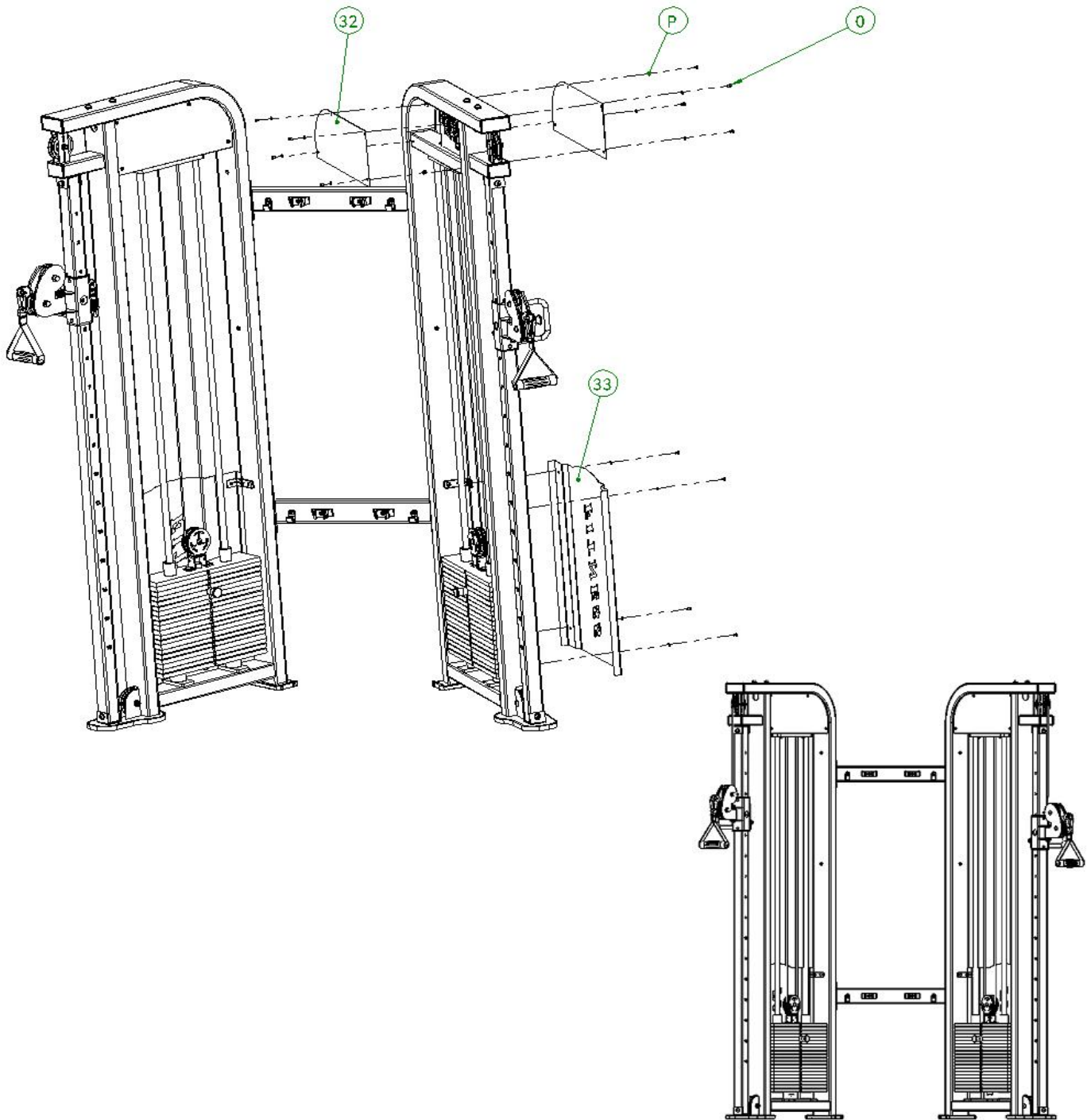

Assembly Steps

Step NO	Item NO	Name	Quantity	Item NO	Name	Quantity
8	No.34	Upper connection assembly	1	N	M10*20 Flat round head screw	4
	B	Φ10 Flat gasket	4			

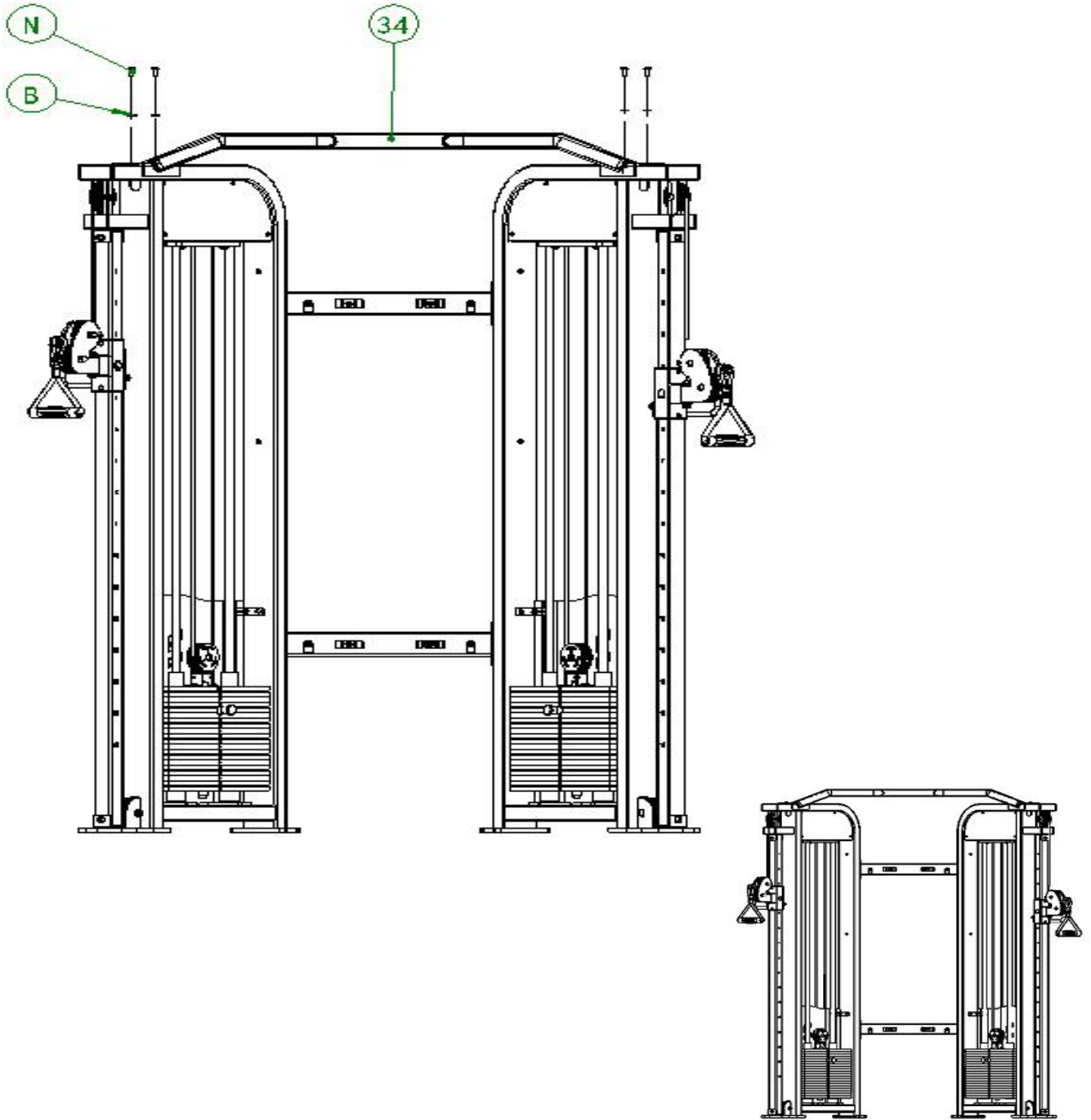

No.34 Upper connection assembly*1pc

Step NO	Item NO	Name	Quantity	Item NO	Name	Quantity
	No.37	Aluminium end cap	2	No.40	Rubber	2
	No.38	Post five-piece set	2	Q	M8*20 Flat countersunk head	2
	No.39	Small yellow spacer	2			

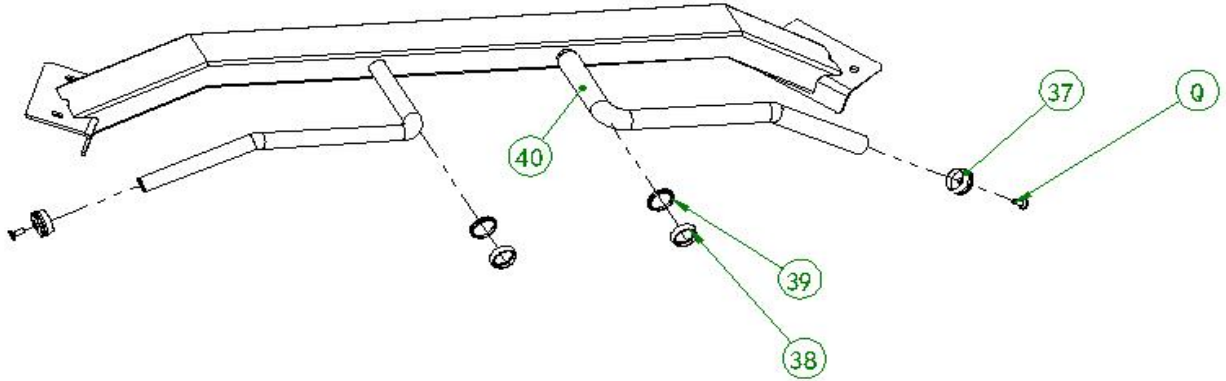

Assembly Steps

Step NO	Item NO	Name	Quantity	Item NO	Name	Quantity
9	No.35	A Push for connection group	1			
	No.36	B Push for connection group	1			

